

# **4L80E MASTER SHIFT RECALIBRATION** **AND ASSEMBLY UPGRADE KIT** **PART # 4L80ECC/MSRK**

This product is for heavy duty and competition usage only. This product should be installed by a professional transmission mechanic who is fluent with servicing the GM4L80E transmission.

This product has been designed, engineered and tested to meet the highest quality standards obtainable for performance, consistency and durability.

With these upgrades the GM4L80E transmission can easily handle 1000 horsepower/750 foot pounds of torque, and with the necessary aftermarket upgrades, reliability at 1500 horsepower/1500 foot pounds of torque range is easily obtainable.

Beyond the 1000 horsepower/750 foot pounds of torque power level, consider the use of an aftermarket input shaft, forward clutch hub, 36 element sprag and drum, intermediate pressure plate, and/or mainshaft.

## **Kit Contents:**

- 1 Purple Pressure Regulator Spring**
- 1 Orange Pressure Regulator Spring**
- 1 Reverse Boost Valve**
- 1 Reverse Boost Valve Bushing**
- 1 .375" Cup Plug**
- 1 Separator Plate**
- 1 Upper Valve Body Gasket**
- 1 Lower valve Body Gasket**
- 1 Accumulator Delete Plate**
- 6 Accumulator Delete Plate Mounting Bolts**
- 1 Fluted Overrun Clutch Housing Bushing**
- 1 Intermediate Clutch Backing Plate Snap Ring**
- 12 Intermediate Clutch Apply/Release Springs**
- 1 Intermediate Clutch Apply/Release Spring Retainer**
- 1 Direct Clutch Piston**
- 16 Direct Clutch Apply/Release Springs**
- 1 Direct Clutch Apply/Release Spring Retainer**
- 1 Upgraded Output Carrier Thrust Washer**
- 1 TH400 Case Bushing**
- 1 Output Shaft to Case Thrust Bearing Assembly**
- 1 Complete Shim Kit**
- 1 Accumulator Valve Bore Plug**
- 1 Shift Solenoid Feed Filter Plug**
- 3 Center Support Sealing Rings**

## Pressure Regulator and Oil Pump Modifications

**Remove Reverse Boost Valve** Remove the OEM Pressure Regulator Spring (230) from the oil pump. Two pressure regulator springs are supplied in this kit. The Violet spring will furnish approximately 185-190 psi maximum line pressure, and its use is recommended for applications up to 650 lbs. ft. The Orange spring will furnish approximately 225-230 psi maximum line pressure, and its use is recommended for applications over 650 lbs. ft. Select pressure regulator spring based on the intended application. All applications install the Reverse Boost Valve and Bushing (228 and 227) See Figure 1.

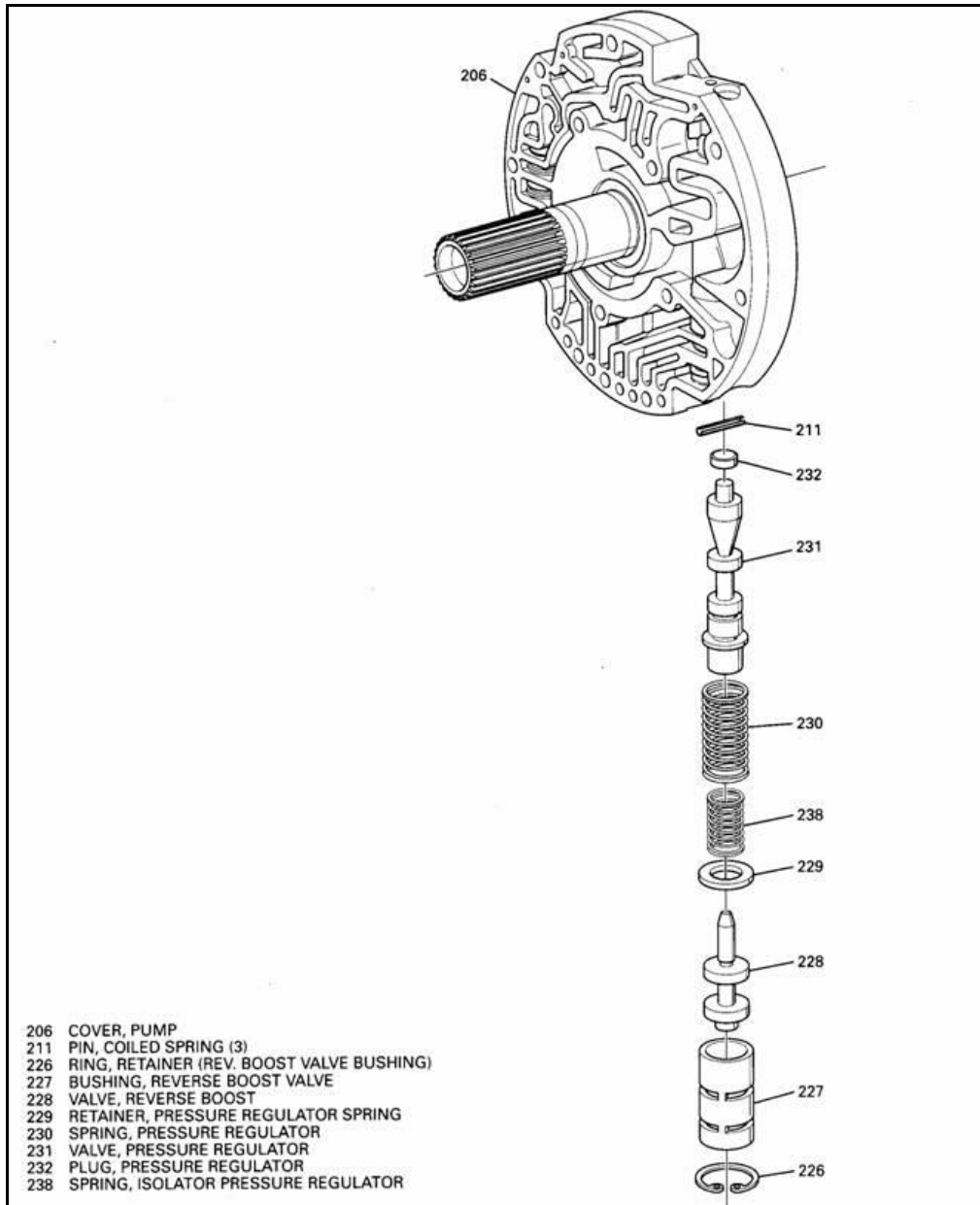

**FIGURE 1**

Drill a .055" to .067" hole between the line pressure and converter charge passages in the pump cover as shown in Figure 2. Center punch hole as a guide for the drill bit. This modification will provide the torque converter with charge oil regardless of pressure regulator valve position. Increased line pressure results in increased internal torque converter oil pressure and volume. This results in an increase in converter drain back oil pressure and volume. The diameter of the seal drain back hole in the pump cover is too small to effectively exhaust this increase in pressure and volume. This will result in front seal blow out. To eliminate seal blowout, enlarge the seal drain back hole in the pump cover with a .250" drill. This will provide adequate exhaust flow. See Figure 3.



FIGURE 2



FIGURE 3

Lube oil to the overdrive section of the transmission is supplied thru the feed passage at the rear of the stator support shown in Figure 4. To increase the volume of lube oil delivered to the overdrive section start by enlarging the feed passage with a .125" drill bit. Be sure to drill at a 45 degree angle to maximize oil flow.



FIGURE 4

## Overrun Clutch Housing Lubrication Upgrades

Use the .125" drill to enlarge the feed passage in the overrun clutch housing as well. See Figure 5. Replace the overdrive sun gear bushing in the overrun clutch housing with the supplied fluted bushing. See Figure 6. The flutes will channel a steady supply of lube oil directly to the overdrive planetary gearset.

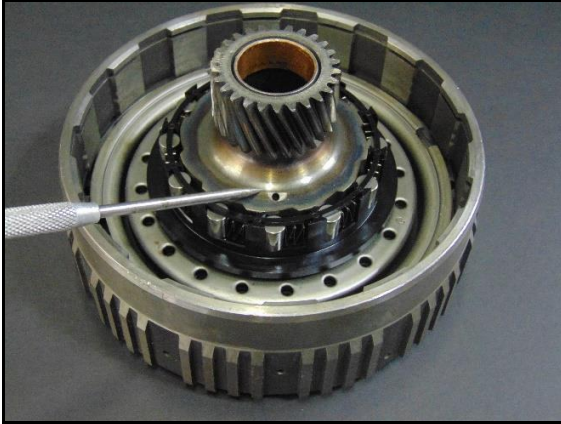

FIGURE 5

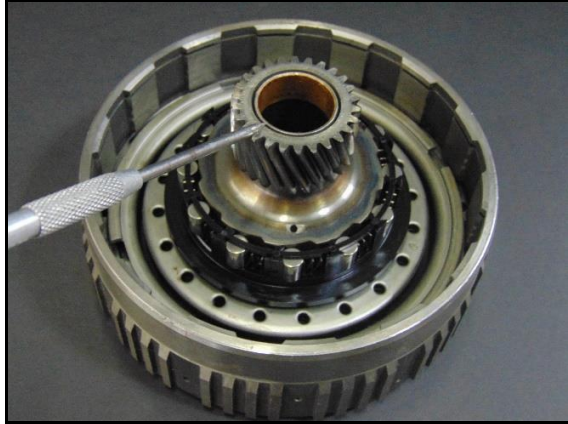

FIGURE 6

## Direct Clutch Housing Upgrades

Replace the direct clutch piston and one piece direct clutch apply/release spring and retainer assembly with supplied direct clutch piston, 16 direct clutch apply/release springs, and retainer. See Figure 7. Remove/do not install the direct clutch center seal. Upgraded piston permits the installation of six OEM .090" thick steel plates and six OEM .080" thick clutch plates. The use of face grooved clutch plates is recommended. Set clutch pack end clearance at .040" to .060".

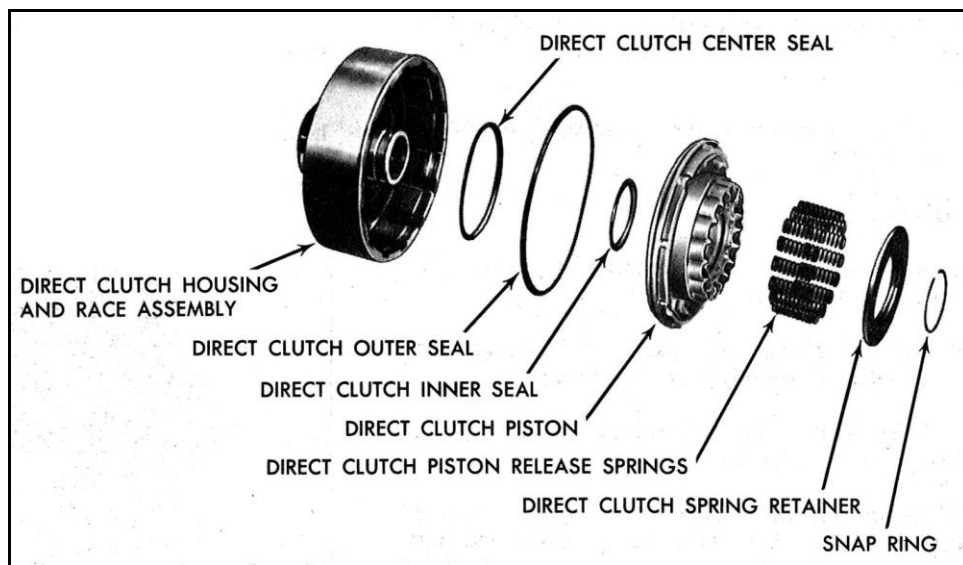

FIGURE 7

## Dual Feed Direct Clutch Upgrade

Dual feeding the direct clutch allows both the inner and outer areas of the direct clutch piston to be exposed to direct clutch apply pressure, instead of just the smaller inner area. This roughly triples the clamping force used to apply and hold the direct pack assembly. Remove/do not install the center lip seal from the direct clutch housing. See Figure 8. Install the 3 supplied sealing rings to the center support as shown in Figure 9. Remove/do not install the second oil seal ring from the top of the sealing ring boss on the center support. See Figure 9.

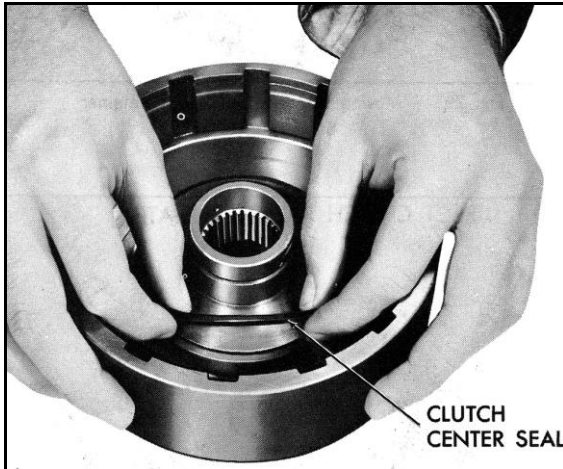

FIGURE 8



FIGURE 9

After the center support has been installed in the case, install the supplied .375" cup plug into the case at the location shown in Figure 10. Be sure the cup plug is seated against the center support.



FIGURE 10

## Center Support Upgrades

Replace the one piece intermediate clutch apply/release spring and retainer assembly with supplied 12 intermediate clutch apply/release springs and retainer. See Figure 11. The use of three OEM TH400 intermediate clutch plates is recommended to reduce shock loading of the intermediate sprag assembly. Set clutch pack end clearance at .040" to .060". Install supplied intermediate clutch backing plate snap ring.

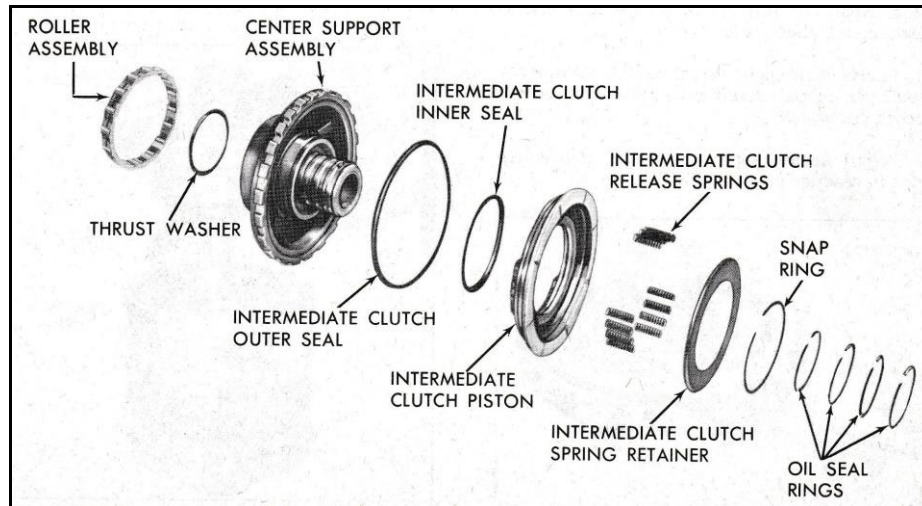

FIGURE 11

Lube oil to the intermediate sprag and intermediate clutch assembly is supplied thru the feed passage in the center support shown in Figure 12. 1997 and up center lube models received a revised casting which included the reduction of this passage down to .067". This reduces the volume of lube oil delivered to these components, raising durability concerns in high load applications. To increase the volume of lube oil delivered to these components, enlarge the feed passage with a .125" drill bit. Be sure to deburr the inside diameter of the bushing after drilling. Always verify the cooler return passage in the support is free of debris and or obstructions by blowing it out with compressed air. See Figure 13.

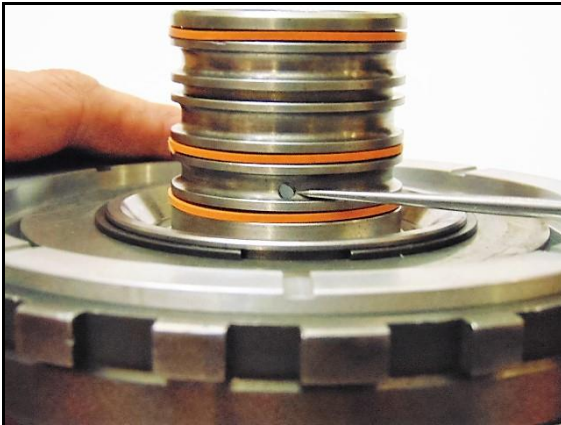

FIGURE 12

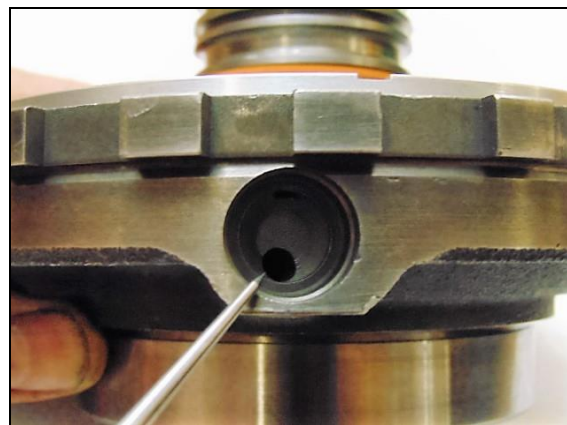

FIGURE 13

## Output Carrier Thrust Washer Upgrade

Discard the OEM output carrier thrust washer and replace with the supplied self-lubricating thrust washer. See Figure 14.

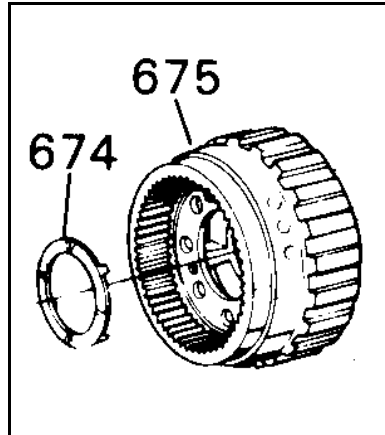

FIGURE 14

## Rear Case Bushing and Thrust Bearing Upgrade.

Discard output shaft to case selective shim and thrust washer and remove case bushing. With 99 and up models remove 2 opposing locating tabs from rear of washer. Install the supplied case bushing so that it protrudes into the case approximately .075". This will provide a register for the output shaft to case thrust bearing assembly and selective shim(s). Do not worry, it is ok that the bushing is wider. This will provide additional support for the output shaft as well as increased anchorage for the bushing in the case as the OEM bushing does not completely fill the case bore. Another bonus is the bushings built in lube channel. Set rear end clearance at .003" to .010".

## Valve Body and Separator Plate Upgrades

Remove the Coiled Spring Pin (303) and Shift Solenoid Feed Filter Plug (316) from the valve body assembly. Replace the plug with the one supplied in this kit. Seat the O-ring in the plug by rolling it several times across a flat surface. Lubricate and install into valve body and reinstall the coiled spring pin.

Remove the Coiled Spring Pin (303) and Accumulator Valve Bore Plug (329) from the valve body assembly. Replace the plug with the one supplied in this kit. Seat the O-ring in the plug by rolling it several times across a flat surface. Lubricate and install into valve body using the supplied bolt as an installation tool. Reinstall the coiled spring pin. See Figure 15.

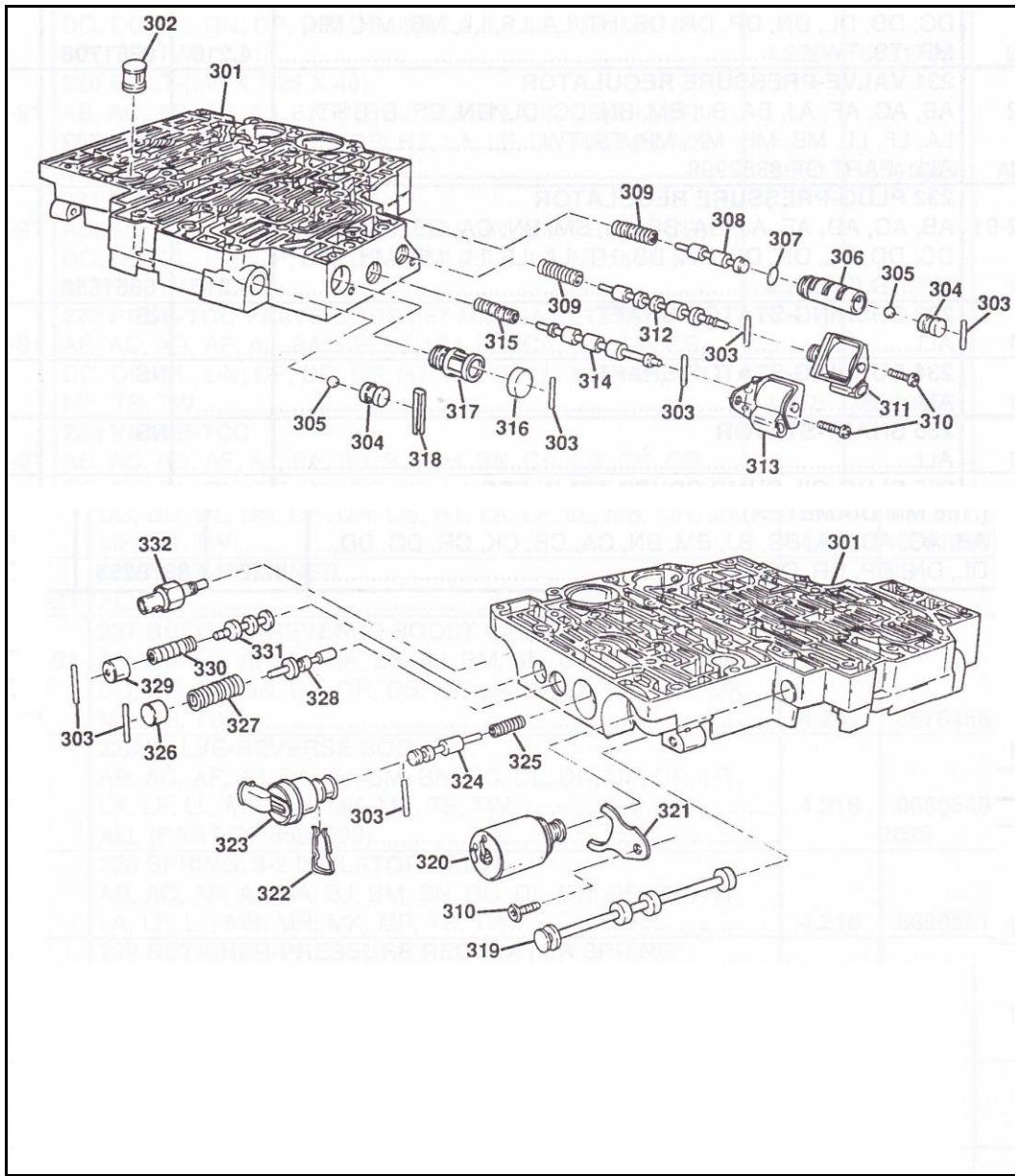

FIGURE 15



With this kit the 3<sup>rd</sup> and 4<sup>th</sup> shift accumulators have been deleted. The only accumulated upshift is the 2<sup>nd</sup> gear shift. Field testing with both OEM and aftermarket clutch plates have generated the following hole size recommendations:

For OEM type shifts leave plate as is.

For applications up to 500 hp use 2<sup>nd</sup> and 3<sup>rd</sup> gear feeds of .093", and a 4<sup>th</sup> gear feed of .082".

For applications up to 750 hp use 2<sup>nd</sup> and 3<sup>rd</sup> gear feeds of .110", and a 4<sup>th</sup> gear feed of .082".

For applications up to 1000 hp use 2<sup>nd</sup> and 3<sup>rd</sup> gear feeds of .125", and a 4<sup>th</sup> gear feed of .090".

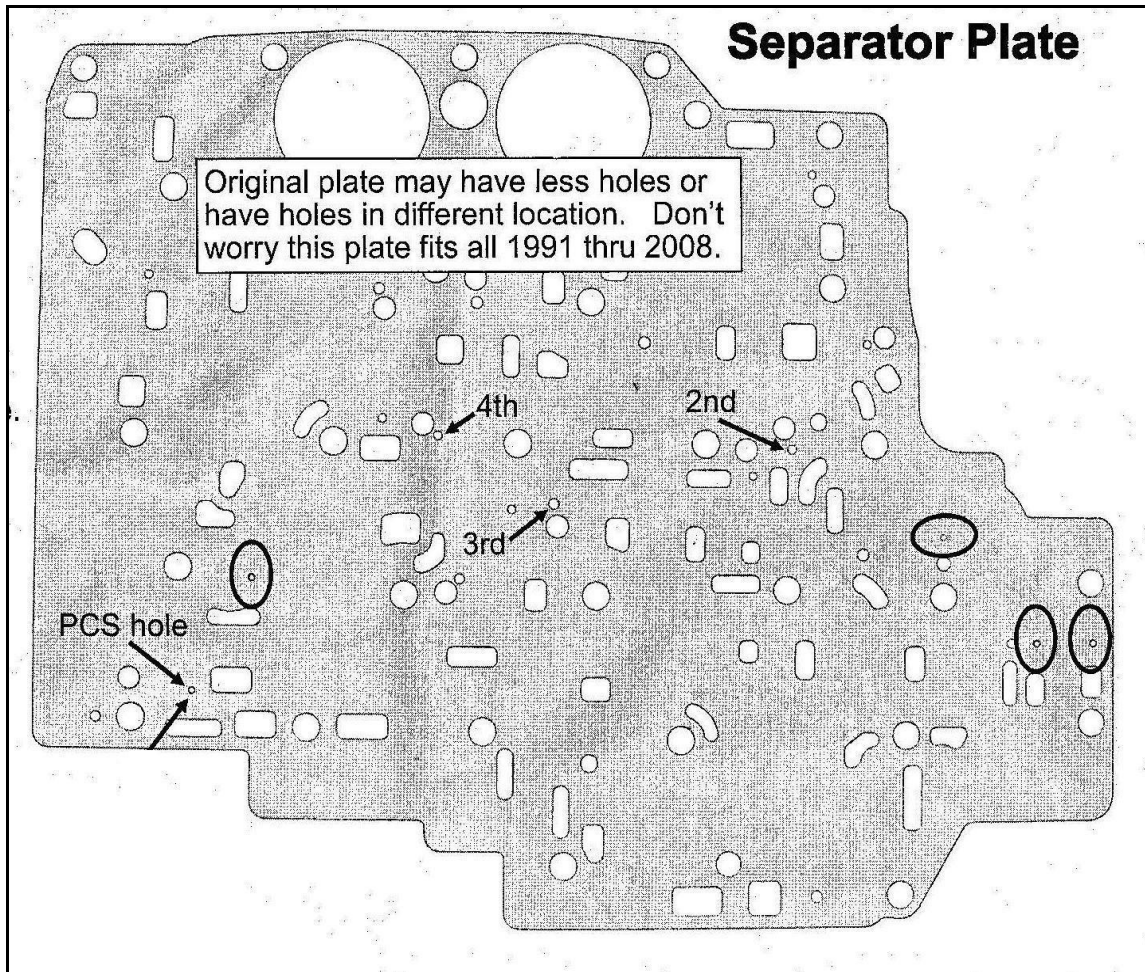

FIGURE 16

With applications beyond 1000 hp, second and third gear feeds of up to .140" may be used. The 4<sup>th</sup> gear feed hole should be no larger than .110".

Install the six supplied Torlon checkballs at locations 1,3,4,8,9,and 10 ONLY as per Figure 17.

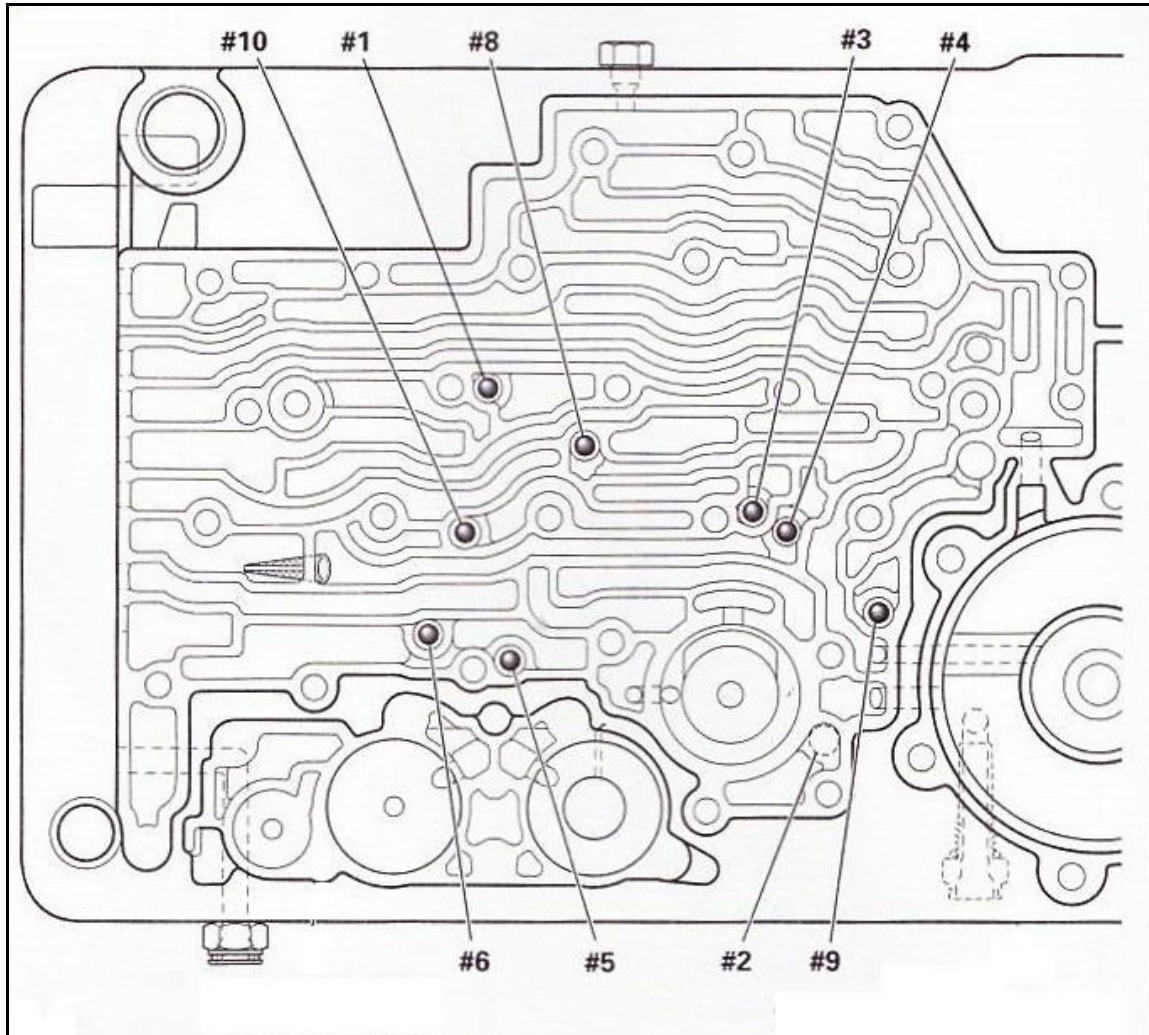

FIGURE 17

Replace the OEM accumulator housing and related components with the supplied accumulator delete plate and mounting hardware. No gasket is necessary between the delete plate and separator plate. Torque the mounting bolts to 130 inch pounds.